



# CA819 Dual Band Amplifier Installation Manual

**Note: Before installing the Cyfre™ Amplifier, please read the entire contents.**

## Section # 1 Parts List

Item	Qty	Description	
1	1	Cyfre™ Amplifier	
2	1	Cyfre™ External Magnetic Mount Antenna with 10ft low loss cable	
3	1	Nylon Ballistic Bag	
4	1	Cyfre™ 12 Volt Cigarette Power Adapter	
5	1	Cyfre™ 4ft Hardwire Power Cable	
6	1	Cyfre™ AC/DC Adapter	

## Section # 2 Tools and Other Materials Required

### Item Description

- 1 Electric drill (as required for signal amplifier mounting holes)
- 2 Screw driver
- 3 Qty 4 screws (length and type as required for signal amplifier mounting)
- 4 Wire cutters / strippers
- 5 Qty 2 wire connection insulators or insulating material (as required for DC power cable connection to 12V DC system)

## Section # 3 WARNINGS!

- ∇ Antenna must be mounted a **MINIMUM** distance of 50 cm (1.64ft) away from any person.
- ∇ An external antenna must be mounted outside the vehicle, if mounting an external antenna on the exterior portion of the outside glass a **minimum of 3 feet of separation is needed. Failure to do so may result in amplifier failure will void your warranty.**
- ∇ **UNDER NO CIRCUMSTANCES CAN AN EXTERIOR ANTENNA BE INSTALLED INSIDE A VEHICLE. Doing so will result in amplifier failure will void your warranty.**
- ∇ The power supply must be plugged into a 12 Volt outlet that is connected to the fuse box of your vehicle and have a minimum of 3 amp fuse.
- ∇ Under no circumstances should you power up your amplifier without first properly connecting a 50 ohm 800/ 1900 MHz dual band cellular antenna to both the internal and external antenna connectors. **Failure to properly connecting the antennas may result in amplifier failure will void your warranty.**
- ∇ For optimum performance and compatibility with your service provider requirements, **it is recommended that the external antenna be installed on the exterior metal roof of your vehicle.**
- ∇ **Use of cellular amplifiers with antennas of higher gain than 6dBi gain is in violation of FCC regulations for which the offender will be fully liable, and void your warranty.**
- ∇ Do not combine the external or interior antenna cable with other coaxial cables. The additional loss of the cable length and connectors could greatly diminish the performance of the amplifier.  
**\*\*\*It is recommended that only qualified or informed installation technicians install this product permanently to a vehicle. Installation by any other person is at the risk of the owner and operator.**

**It is recommended that only certified automotive installation technicians install this product in a vehicle. Installation by any other person is at the risk of the vehicle owner and operator.**

## Section # 4 Installation: *Selecting a Suitable Location to Mount the Signal Amplifier*

- ∇ Antenna must be mounted a **minimum** distance of 50 cm (1.64ft) away from any person(s).



- ▽ You may place your amplifier anywhere inside your vehicle (except as mentioned above). The amplifier's location should be easily accessible and mounted away from moving parts, excessive heat or moisture.
- ▽ The exterior antenna must be mounted outside the vehicle and at a distance that can be reached from the supplied antenna cable.

### Section # 5 Installation Cautions

- ▽ Use caution to avoid drilling through or near fuel lines or fuel tanks; brake lines; or electrical wiring.
- ▽ Do not mount the amplifier or its associated wiring in a location that may interfere with the safe operation of the vehicle.
- ▽ If the fuse is changed from the 3 amps to a higher rating the warranty is void. Purchaser of the amplifier would be responsible for the repair of the unit.
- ▽ Caution: Connection to the negative side with the positive lead will cause damage to the amplifier.

### Section # 6 Installation of In-Vehicle Amplifier

To meet the FCC Exposure Guidelines, the antenna should be installed so there is at least 20 cm of separation between the body of the user or nearby persons and the antenna.

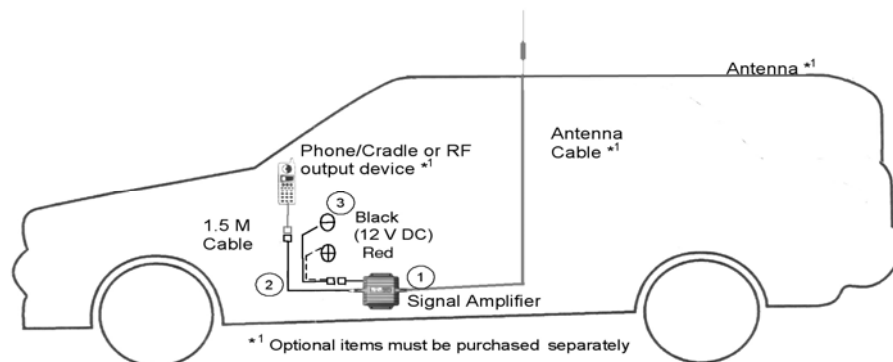

Use a 3dB antenna for Optimal Performance

### Typical Installation For Under the Seat Mounting

1. For safety, disconnect the vehicle's negative "-" battery terminal to remove power from the vehicle.
2. Drill holes and mount the signal amplifier (ITEM 1) in the selected location.
3. Connect the red wire of the supplied 2 Meter (78") power cable (ITEM 2) for the signal amplifier to a positive connection on the vehicle's electrical system. Choose a 10 to 30 Volt DC circuit that is: fuse protected; and ignition switched. (Often referred to as the "Accessory output")
4. Attach the solid black wire of the supplied 2 Meter (78") power cable (ITEM 2) to a vehicle electrical ground point.
5. Attach an external antenna cable (6dbi max) to the amplifier's antenna connector. The "Phone" connector on the amplifier is connected to a cellular phone handset via a RF cradle or an RF cable. You may also connect the optional RF cable for your handset, from the cellular handset to amplifier port labelled "Phone".
6. Reconnect the vehicle's negative "-" Battery terminal.

### Section # 7 Limited Warranty

Cyfre™ warrants that this product is free from any defects in material or workmanship for a period of one year. If a defect in material or workmanship is found, Cyfre™ agrees to repair or replace the product at its own discretion, free of charge, to the original purchaser excluding all shipping charges. To return product, all parts, packaging, and accessories along with original receipt from where you purchased your product must be included with your return. Failure to return all product, parts, packaging, and accessories will result in voiding your warranty. The warranty is void if the product has been modified, abused, tampered with, or subjected to abnormal conditions. Any use of non Cyfre™ antennas or cables will void your warranty.

Cyfre™ · 2282 Townsgate Road · Building 1 · Westlake Village, California · 91361 · tel: 805-777-1100 · fax: 805-777-8232 · email: info@cyfre.com